

# AGH125

CNC Horizontal  
Gear Hobbing Machine

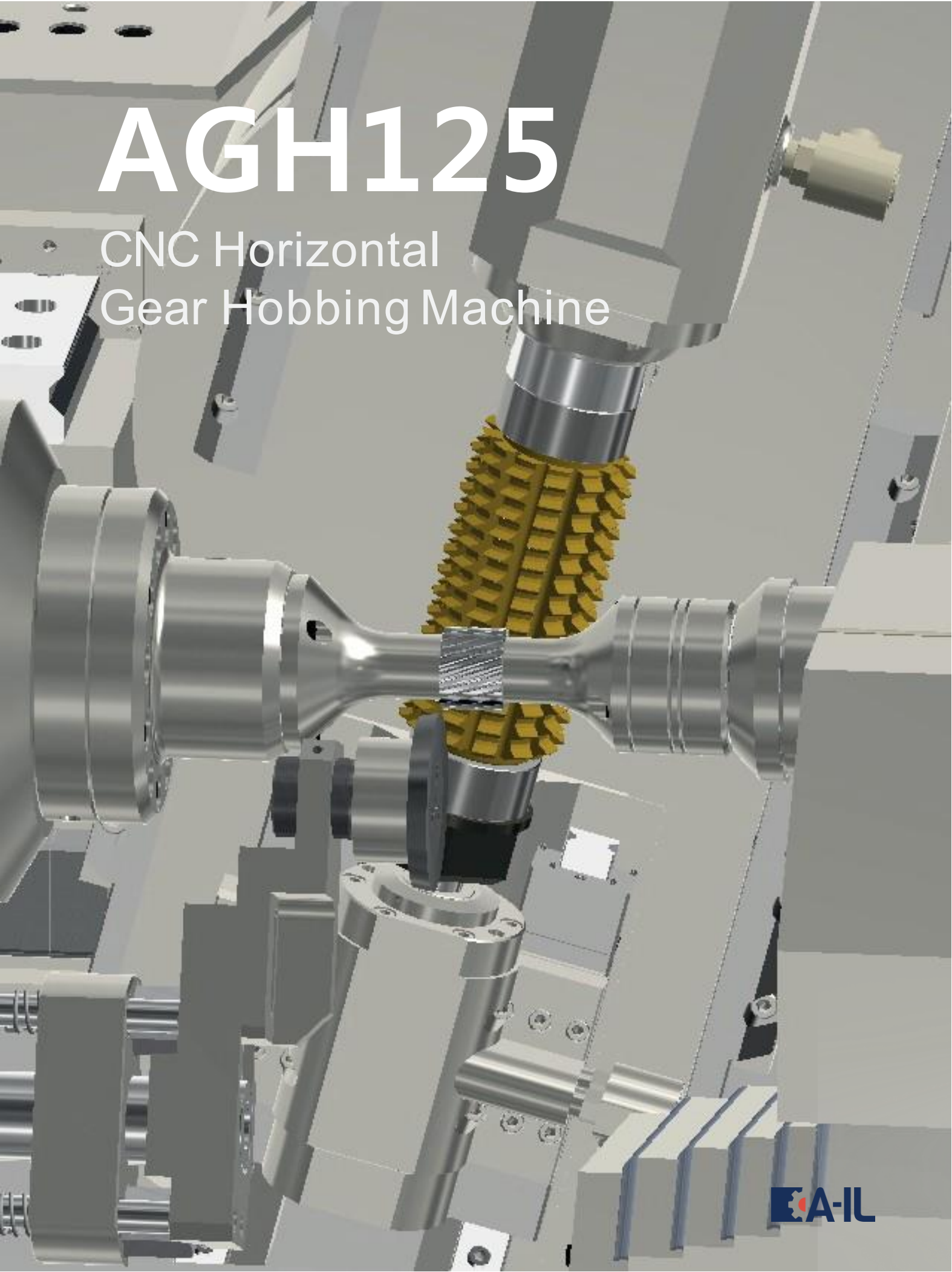

# CNC Horizontal Gear Hobbing Machine



고속·고강성·고효율  
수평형 소형 호빙



6 axis

6축 및 1 스피들  
Full CNC 제어

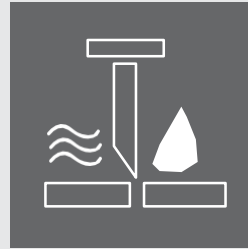

Dry cut(Standard)  
Wet cut(Optional) 가공

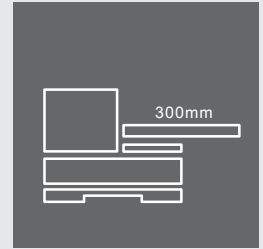

최장 300mm 샤프트  
소재가공 가능



# Details of AGH125

Built-in Work table 및 Hob spindle 적용 BACKLASH "0(Zero)"

## WORK TABLE

Built-in Motor 적용

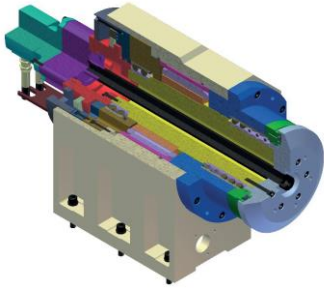

## HOB SPINDLE

Built-in Motor 적용

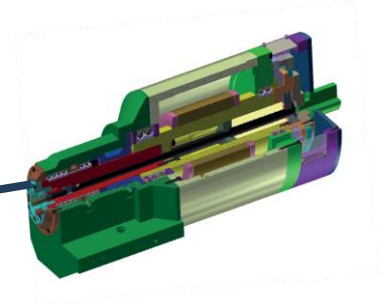

## SUPPORT UNIT

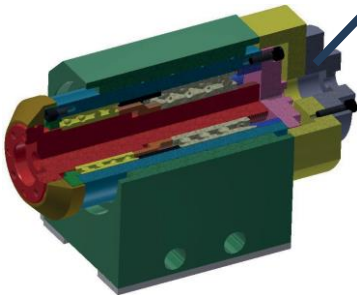

## HOB HEAD SWIVEL

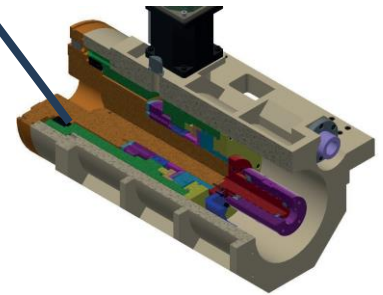

- ▶ 경사 베드 구조에 따른 편리한 작업성 및 원활한 Chip 배출
- ▶ 경사 TYPE BED 구조 및 고강성 ROLLER GUIDE 적용 (X/Z/W축)
- ▶ Z축 경사 구조로 OBD 변화 최소화
- ▶ 본체와 일체형의 초고속 소재공급 장치 (Option)
  - 좌우 주행 : 1축 NC
  - 상하 : 2축 Pneumatic
  - Work grip : Pneumatic

**X axis : Hob radial**

**Z axis : Hob axial**

**Y axis : Hob shift**

**A axis : Hob head swivel**

**W axis : Support unit**

**B axis : Hob spindle**

**C axis : Work table**

# Main Specifications

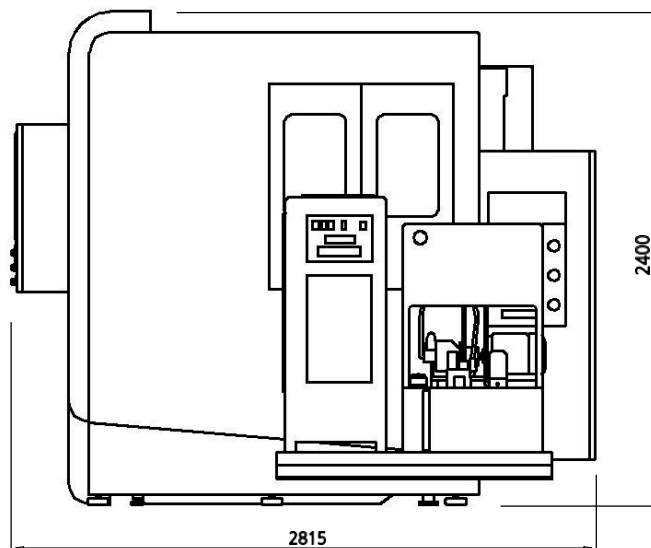
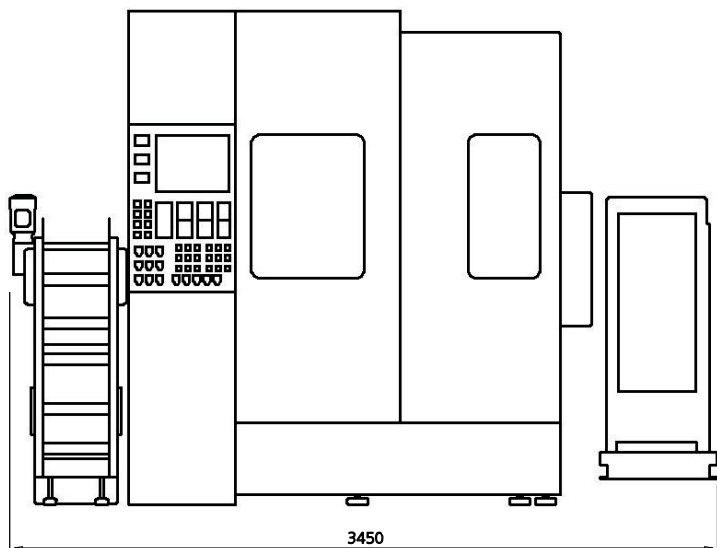

Maximum outer diameter of workpiece  
 Maximum length of workpiece  
 Maximum module of workpiece

Φ130mm  
 300mm  
 M3

Maximum outer diameter of hob  
 Maximum length of hob

Φ100mm  
 180mm

Maximum revolution speed of hob spindle  
 Maximum revolution speed of work table  
 X axis (hob radial) traverse  
 Z axis (hob axial) traverse  
 Y axis (hob shift) traverse  
 A axis (hob head) swivel angle

5,000rpm  
 1,000 rpm  
 125(30~155)mm  
 395(100~495)mm  
 180mm  
 -45°~+45°

Total power required  
 CNC Controller  
 Tool monitoring system (Option)  
 Machine weight

30kVA  
 FANUC 0i series  
 8,000kg

## Head Office Factory

울산광역시 북구 효자로 54  
<http://www.ails.kr>

E-mail:ails@ails.co.kr T  
 el : +82 52-287-7291  
 Fax : +82 52-287-7296

## INDIA Corporation

No.24, Lakshmi Nagar, (Near Sumathi Theater),  
 Sriperumbudur-602105, Kanchipuram(Dt)  
 TamilNadu, Chennai, India

E-mail:a01054611855@gmail.com  
 Tel : +91-89398-97183  
 +91-89398-97184

## CHINA Corporation

Tower B, No.36, Quanjing industrial park, No.10 LiuShan  
 Street, YingBin Road(North), YanJiao development zones.  
 SanHe City, LangFang City, HeBei Province.

Email:spar2033@daum.net  
 Tel : +86-186-2202-7574  
 +86-158-1105-2810